

# EQUALIZER

---

# SYSTEMS

A **DAYS** COMPANY

(800) 846-9659

equalizersystems.com

## EQ Smart-Level Installation/Operation/Warranty Guide

Effective May 2018

### Contents

Required Tools & Parts	Page 2
Installation	Page 2 - 7
Jacks	Page 3
Pump/Fittings/Hoses	Page 4
Wire Harness/Pump/Install Control Panel	Page 5 - 6
Chassis Interface Connection	Page 6 - 7
Purging	Page 7 - 8
Control Panel Programing & Setting the Null	Page 8 - 9
Operation	Page 9 - 10
Panel Indicators	Page 11 - 12
Manual Override	Page 12 - 15
Warranty	Page 12
Diagrams	Page 13 - 24

This manual is intended to be used by technicians installing Equalizer Systems Level-Lite systems. It is assumed that the reader is familiar with hydraulic, mechanical, and electrical systems; in addition to workplace safety.

EQ021R1

## Required Tools & Parts

### Tools Required for Installation

- Ratchet, sockets and wrench set
- Wire cutters / crimpers
- 2000 r.p.m. electric drill/screw gun and bits
- Welding equipment (if welding leg or bracket in place)

### Additional Items Required for Installation

\*\*The following cables, connectors and breakers can be purchased from Equalizer Systems – Part # 70103

- #4 AWG power wire \*\*(to connect battery + 12V positive to the pump) \*
- #4 AWG ground wire \*\*(to connect battery - 12V ground to pump) \*
- #4 AWG ring terminals \*\*
- Loom clips (to secure harness and hydraulic hoses to the coach)
- Self-drilling screws or pop rivets
- Wire ties
- 10 – 16 quarts Automatic Transmission Fluid (Dexron or multi-purpose)

\*Note: These items must be #2 AWG or larger if cable run is greater than 12 ft

### \* Caution \*

Modification of any factory supplied item may result in the denial of all warranty claims. Call Equalizer Systems Technical Support prior to any modifications

With any hydraulic application, holding position on a cylinder must be done with safety in mind. Failure in the system may cause the jacks to retract or extend suddenly. When working under or near the coach, always use jack stands of appropriate rating to support the weight of the coach.

## Jacks

Determine where the jacks will be mounted. The jacks must be mounted to the chassis frame, as close as possible to the front and rear axles.

Secure the jack brackets in place according to the bracket mounting drawings. Bolt the jack to the bracket using the supplied nuts and washers. The jacks must be installed with a minimum of 6 inches of ground clearance. See Installation chart below. In any case, the bottom of the footpad should be no lower than any other item mounted on the coach. Pay particular attention to the angle of departure for the chassis when mounting the rear jacks – and the angle of approach when mounting the front jacks.

### Reference Chart for Installing Jacks:

The foot/pad must be mounted with-in the range suggested (see chart below) for proper operation of the system. Retract the jack fully (jack up). Ground clearance is determined by measuring from the bottom of the jack foot to the ground (jack retracted fully). When in doubt call Equalizer Systems 800-846-9659 ext 339

6 to 7 inches of ground clearance required

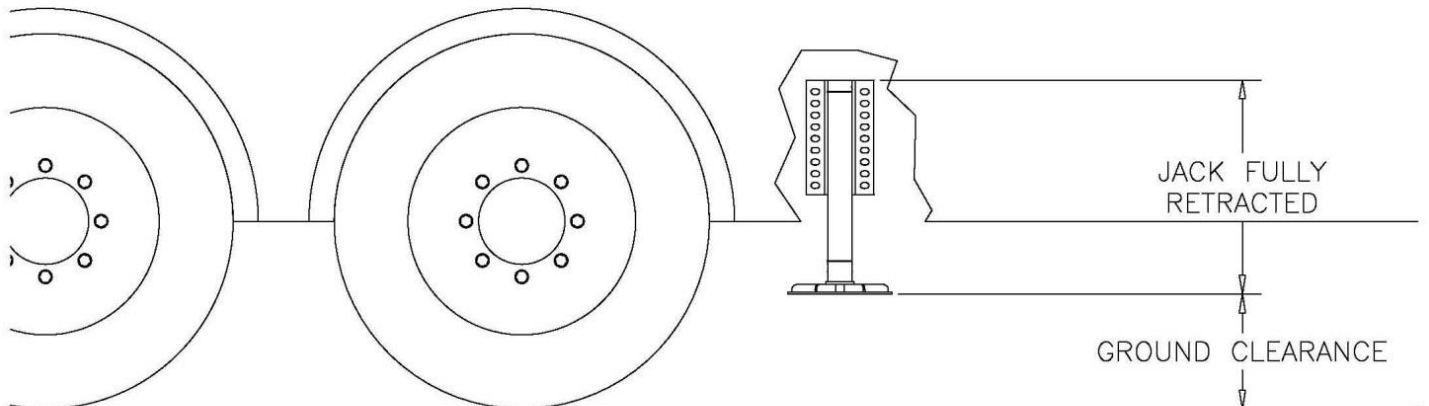

## Pump

Install the pump kit on the coach. The pump must be mounted in a location that is reasonable to route all of the hydraulic hoses to the manifold. It must be accessible for filling the reservoir and monitoring the fill level. The cartridge valves and the end of the motor must be accessible to manually override the system (see instructions for manual override). See the drawings for attachment of the pump mount bracket.

## Fittings

Install the hydraulic adaptor fittings in the top and bottom of each jack and install the fittings into the manifold. The straight thread o-ring side always goes to the cylinder or manifold. The tapered side will get the hose attached to it. When installing straight fittings into the leg or manifold, tighten to 15 lbs-ft. When using 90 degree fittings, turn until finger tight, position correctly, then tighten the jam nut to 15 lbs-ft.

## Hose

Install the hydraulic hoses according to the chart below. Route the hoses clear of all hot exhaust components and pinch points in the suspension/chassis system. Attach the hoses to the manifold and jack fittings (from step 4). Tighten to 15 lbs-ft. Secure the hydraulic hoses with wire ties or loom clamps to the chassis. Care should be taken to not kink or twist hoses. The minimum bend radius is 6 inches.

### Installation of Hoses to the Manifold:

#### Jack Leg

Left Front – Top  
Left Front – Bottom

Right Front – Top  
Right Front – Bottom

Left Rear – Top  
Left Rear – Bottom

Right Rear – Top  
Right Rear – Bottom

#### Manifold Connection

Brown Solid (T-1)  
Brown Stripe (B-1)

White Solid (T-2)  
White Stripe (B-2)

Orange Solid (T-3)  
Orange Stripe (B-3)

Yellow Solid (T-4)  
Yellow Stripe (B-4)

## Wire harness

Route the wire harness from the pump assembly to the area where the control panel is to be mounted. The harness needs to be routed away from moving objects, sharp edges and high heat sources. Use wire ties and or loom clamps to secure in place. The end with the 9 pin and 2 pin connector goes to the pump assembly. See the drawing for the lay out. Connect the harness connectors to the matching connectors at the pump assembly.

## Uni-Directional Motor Pump #1551

### Power Connections:

Attach a # 4 gauge wire (# 2 gauge if the run is over 12ft.) between the positive +12v terminal on the battery and the battery post at the motor solenoid on the pump. This solenoid post will generally have a yellow fused wire attached to it that supplies power to the controller. This battery connection may be fused at the source with a 150-amp circuit breaker. This +12v supply must be a dedicated and isolated circuit (not shared with other devices), and must be constant, non-switched +12v.

Attach a # 4 gauge wire (# 2 gauge if the run is over 12ft.) between the negative -12v terminal on the battery and the ground stud on the pump. This is the preferred method of grounding. If grounding the pump to the chassis, the connection must be sound, free of paint and not susceptible to corrosion. The battery connection to the frame must also be of 4 gauge or larger cable. It is not acceptable to allow the pump mounting bolts to be the sole grounding connection.

## Bi-Rotational Motor Pump #'s 2390, 2532, 2542, 3043, 3195

### Power Connections:

Pump #2390, 2532, 2542: Attach a # 4 gauge wire (# 2 gauge if the run is over 12ft.) between the positive +12v terminal on the battery and the common posts on the motor solenoid. This supply may be fused at the source with a 120-amp circuit breaker. This +12v supply must be a dedicated and isolated circuit (not shared with other devices), and must be constant, non-switched +12v.

Pump # 3043 & 3195: Attach a #4 gauge wire from the positive + 12V terminal on the battery to the + terminal on the motor contactor (solenoid). This terminal has a + beside it on the contactor, also there will be a yellow fused wire on this terminal.

All Pumps: Attach a # 4 gauge wire (# 2 gauge if the run is over 12ft.) between the negative -12v terminal on the battery and the ground stud on the pump. This is the preferred method of grounding. If grounding the pump to the chassis, the connection must be sound, free of paint and not susceptible to corrosion. The battery must be connected to the frame with #4 gauge or larger wire. It is not acceptable to allow the pump mounting bolts to be the sole grounding connection.

## EQ Smart-Level Control Panel

Fasten the control panel in the desired location (near the driver's seat, if applicable). The control panel can be mounted vertically or horizontally. It may be mounted as much 30 degrees from vertical or horizontal. It may not function well right at 45 degrees. The best most accurate will be right at horizontal (zero degrees) or vertical (right at 90 degrees). It may be mounted on any surface regardless of its orientation to the front of the coach. Examples; on the dash, center console, vertical wall, cabinet wall or other firm structure. The control panel is not waterproof or water resistant therefore it must be in an interior location or compartment protected from the environment and spill areas. Attach the supplied wire harness between the Control Panel and the location of the pump assembly. Basically, there are two connectors one is a 12-pin double row the other is a 3 pin which is the power and ground feed for the control panel. There may be additional optional connectors that are not used for most installations. There may be additional wires breaking out of this harness, they are discussed below in chassis interface.

The control panel must be firmly mounted to a surface that 'reacts' with the coach during leveling. The Auto Level function requires this as the leveling sensors are located inside of the control panel. Also, a set up process known as Orientation Program followed by setting the null (described later) must be performed. If these steps are not properly completed the Auto Level function will not operate properly. See orientation setting and null setting for these processes.

## Chassis Interface Connections

Please note that Step 1 and 2 are required. Step 3 is optional.

### Step 1 - Keypad Ignition Disable Circuit:

Note the "break-outs" near the end of the keypad harness. The Pink wire must receive a +12 VDC Input when the ignition key is in the "on" position. Connect this wire to the ignition positive. This will make the wire "hot" and will inhibit jack extension when the vehicle ignition key is in the on (engine run) position. This also provides for a "jacks down" warning in the event of a jack drifting from the stowed position during travel. This connection is required. Failure to make this connection may create an unsafe condition and may void the warranty.

### Step 2 - The Black w/ Yellow wire must receive a Ground Input.

This Black w/ Yellow wire must be connected to a chassis ground. If this wire is not connected to ground the Engage Park Brake light will be on and Auto Level will be Denied.

### Step 3 -Optional Park Brake Connection for Black/yellow wire:

Contact your chassis manufacturer to verify park brake chassis connection and location. This connection must be done by a technician qualified for chassis electrical systems. Most chassis manufactures are now doing this thru the Dash Module. Attempts to connect this improperly could lead to dash feedback or other issues. This connection to a park brake signal is optional. If this input is not connected to the park brake signal or to ground, AUTO-LEVEL will be continuously denied. Also, the engage park brake light will be on if the panel is powered up or the key is in the on (engine run position).

\*Note on items 1 and 2: If Black/Yellow is connected to a park brake signal (as in step 2) and the pink is connected (required) as in Step 1, an automatic "all retract" will be initiated if the key is turned on (engine run position) and the park brake is released.

## Purging Uni-Directional Pump #1551

The jacks are shipped in the fully retracted position. The retraction side of the cylinders is the first to be purged of air. This procedure outlines the steps taken if the jacks need to be purged of air following repairs, etc.

Do Not Manually Overextend Individual Jacks Singlarly This May Cause Unwanted Stress on the Coach or the Jacks

**Retraction Purge:** The retraction side of the cylinders is the first to be purged of air. Fill the reservoir fully with Dexron Transmission fluid. This is the same fluid used in GM vehicles. Begin to purge the retraction side of the system by pushing the UP Button for each jack or by pressing All Retract. The jacks may be run in pairs (front pair & rear pair). You will know when the retraction side of the hydraulic circuit is purged when the fluid level in the reservoir stops and the pump changes sound (bypass mode). Release the keypad button(s). Repeat this process for the rear jack(s). Refill the reservoir to full.

**Full Purge:** Next, cycle the system by lowering each jack to the ground manually, using the DOWN buttons on the keypad. Do not allow the jack to lift the coach. After all jacks are in contact with the ground, press All Retract to retract the jacks. Next run the jacks in pairs (front pair & rear pair) to full extension. Monitor the fluid level and all fittings for leakage. Retract the jacks by pressing All Retract. Recheck the reservoir and fill to full. Note the fluid level in the reservoir is at maximum when all jacks are fully retracted and minimum when jacks are fully extended. This full extension and retraction in pairs should be repeated 3-4 times.

Allowing the air to dissipate through the reservoir and maintaining the reservoir fluid level will get things working faster.

## Purging Bi-Rotational Pump #'s 2390, 2532, 2542, 3043, 3195

This procedure must be performed with the initial installation & running of hydraulic system, and following installation of the pump assembly and jack(s). This procedure applies only to MH-4 systems that are equipped with the Bi-Rotational pump. All electrical and hose connections must be completed before the purging process. You Must Follow this Procedure Strictly. Any Deviation from the Process will cause the purging process to become difficult and time consuming.

Fill the reservoir with ATF Dexron.

Remove the fitting that is installed into port G-1 or attach a hose to the coupler. Place into a clean container. This will allow retract side air to escape to atmosphere.

Run the pump to extend the jacks(s). Maintain the fluid level in the reservoir between 1/4 and 1/2 full. Do not allow the reservoir to run empty. If jacks(s) will not fully extend, crack loose the upper hose(s) at the jack(s) and run the pump to extend until air is expelled. Use Caution - hydraulic fluid will be under high pressure. Retighten the hoses and complete the extension of the jack(s). Maintain the fluid level as described above.

Reinstall the fitting or plug into G-1 or remove the hose attached to the coupler. (See # 1 above)

Run the pump to retract the jack(s). Maintain the fluid level as above. Do not fill the reservoir to full until after the legs are fully retracted.

If fluid in reservoir appears to be aerated (foaming), allow unit to rest until foam dissipates (approx 5-10 minutes).

Fully extend and retract jack(s) a minimum of 3 times. Allow any foam in the reservoir to dissipate as needed. Maintain the fluid level in the reservoir as needed.

## EQ Smart-Level Control Panel Programing

After the system is fully installed the control panel must be programed for operation. Failure to do this will result in a failed or improper Auto-Level. There are basically two program settings the orientation setting and the null setting. that must be done in the following order.

### Orientation Setting:

This process cannot be completed until after the system has been connected to power and the control panel has been mounted and all electrical harness connections have been completed. This process teaches the control panel where the front of the coach is and how the control panel is mounted (vertical or horizontal). If this process is not performed correctly the processor will not know where the front of the coach is. It is possible that without doing this process it may work on a level floor/shop environment however when at sites where the system needs to operate specific legs for leveling it very likely will operate the improper legs. Once this process is properly completed the setting will be "retained" in the control panel and should not ever need to be done again.

With the control panel off press and hold the all retract button then while holding it press the power button, then release both buttons. The power light will start blinking and you will hear a rhythm beeping, also the 4 jacks down indicator lights will be on. Next the orientation is selected by pressing one of the manual control arrows. The exact specific one is determined by how the panel is mounted (see examples below). You will select up arrow if the panel is mounted vertically and down arrow if it is mounted horizontal. The specific one is the one that most relates to the front of the coach.

### Examples:

If the panel is mounted vertically in the dash so that you are looking at it when sitting in the driver's seat. You would push the up arrow for the front jacks.

If the panel is mounted horizontal and in a side surface next to the drivers left arm, then you would push the down arrow for the right-side jacks.

If the panel is mounted vertically in a cabinet wall so that when you are looking at it, you are facing the rear of the coach then you would press the up arrow for the rear jacks.

Note: if you are not clear on this process check our web site for video and/or call Equalizer Systems for assistance.

### Setting the Null:

Null is the term used to indicate the levelness of the coach. A null setting was done at the factory so that the system will try to level, however most likely it will need to be set after the installation of the control panel as the leveling sensor is in the panel. With the coach sitting somewhat level on the shop floor and with the panel power off, depress and hold the Auto-Level button and then press and release the power button Do not release the Auto-Level button and listen for a series of beeps. After the keypad has beeped 5 to 6 times, release the Auto-Level button (the keypad will continue to beep as long as the Auto-Level button is held). The new null has been set and the panel will maintain this setting. This process may need to be completed later following an Auto-Level process if the coach is not level.



# Operation

## Auto-Level Operation

Push and release the power button to engage power. The LED light next to the power button should be lit RED when power is on. You will need to have the ignition key in the off position to extend the jacks. If you attempt to manually extend jacks or all jacks with the Auto-Level button, you will hear a deny tone from the keypad if the ignition key is in the on (engine run) position. Also depending on if the park brake disable is connected and the park brake is released you may not be able to extend jacks.

Press the Auto-Level button and release. The system will send out a continuous series of beeps and the “Operating” LED will be on to let you know Auto-Level is operation and will automatically level the coach. Do not move around or exit the coach during this operation, doing so will fault out the operation or result in an incomplete leveling/stabilization operation. When completed, the Keypad will signal the successful completion with a dual-stage tone. The Keypad may be left on once level has been achieved. The Keypad will enter “sleep mode” after five minutes of inactivity.

Note: Auto level will be denied if the jack indicator lights are on. To clear this press all, retract then perform auto level.

Setting the Null: Null is the term used to indicate the levelness of the coach. A Null setting should have been performed by the installer. If the coach is not level following an attempt to Auto-Level, you will need to level the coach and reset the null. To set the null, push and release the Power button on the Keypad to engage power. The LED light next to the Power button should be lit RED when the power is on. Level the coach by deploying jacks manually, or by simply parking the coach on a level site. You do not need to have the jacks deployed to set the null. Use a bubble level on a flat surface in the center of the coach as a reference. Once the coach is level, turn the power off at the panel. Depress and hold the Auto-Level button and press and release the Power button and listen for a series of beeps. After the Keypad has beeped 5 to 6 times (the Keypad will continue to beep as long as the Auto-Level button is held) release the Auto-Level button you should get a confirmation beep. The new null has been set and the panel will store/remember this setting. Press and release the All Retract button to retract the jacks to the stowed position.

Use the All Retract button to retract the jacks prior to travel. This system does provide the ability to retract the jacks using the UP buttons for each pair of jacks. However, these buttons are not intended to be used for retracting the jacks to their stowed position prior to travel. The Up arrows are to be used only for retracting the jacks to help level the coach. The All Retract button must be pressed to insure the system is ready/safe for travel. All jacks should automatically retract and return to stowed position when the ALL RETRACT button is pressed and released. The pump will run in retract for approximately 5 seconds after the last jack has been fully retracted- or until a time limit of 90 seconds has been reached.

\*It is always the responsibility of the coach operator to visually confirm that the jacks are fully retracted and safe for travel\*

## Helpful Hints

- Do not allow motion in the coach during the Auto-Level operation (don't move around in the coach). This could cause the system to fault out or level/stabilize improperly.
- The Auto-Level is a microprocessor-controlled system. Proper and adequate battery voltage and permanent chassis ground are essential.
- Your system is equipped with override ability. Refer to the procedure for proper use of this. It is usually better to review this procedure prior to its actual use, rather than having to learn a new procedure in difficult environments and or situations. This is designed to get the jacks retracted in the event that there has been a power/control failure.

- If the system has not been used (with the jacks stowed) for over 24 hours, it is recommended that you engage the All Retract button prior to travel in order to re-pressurize the system.
- A lubricant, like WD40, may be used to clean and lubricate the cylinder shafts.

## Manual Operation

Push and release the Power Keypad button to engage power. All lights will come on then most will go out. The LED light next to the Power button should be lit RED when power is on. You will need to have the ignition key switch in the off position to extend the jacks. If you attempt to extend individual jacks by pressing the Down Keypad buttons or all the jacks with the Auto-Level button, you will hear a “deny” tone from the keypad if the ignition key is in the improper position. Also depending on if the park brake disable is connected and the park brake is released you may not be able to extend jacks. (See step 9 on page 5).

Using the Down Keypad button, extend the jacks until they contact the ground (this is referred to as “planting” the jacks). As you extend the jacks, an LED light on the Keypad will indicate the jack(s) is out of the “stowed” position. Jacks may only be operated in pairs using the manual keypad buttons.

Use a bubble level on a flat surface in the center of the coach. Level the vehicle by using the Down or Up Keypad buttons until the vehicle is level. Jacks may be operated only in pairs on later model units. The Keypad may be left on or powered off once level has been achieved. The Keypad will enter “sleep mode” after five minutes of inactivity.

Use the All Retract button to retract the jacks prior to travel. This system does provide the ability to retract the jacks using the UP buttons for each pair of jacks. However, these buttons are not intended to be used for retracting the jacks to their stowed position prior to travel. The Up arrows are to be used only for retracting the jacks to help level the coach. The All Retract button must be pressed to insure the system is ready/safe for travel. All jacks should automatically retract and return to stowed position when the ALL RETRACT button is pressed and released. The pump will run in retract for approximately 5 seconds after the last jack has been fully retracted- or until a time limit of 90 seconds has been reached.

Check/test the following: If you have properly installed the ignition disable circuit, the jacks will not extend if the ignition key is in the on (engine run position). And the ignition on LED should come on. When you turn the key off the LED should go out and allow extension. This is a required connection/step. Failure to properly connect this could create an unsafe condition and may void the warranty.

\*It is always the responsibility of the coach operator to visually confirm that the jacks are fully retracted and safe for travel\*

## Blue Tooth Operation

The EQ Smart-Level control panel is equipped with built in Blue Tooth control ability. To use this from your smart phone down load the Blue Tooth App from our web site (direct link) or go to the Google Play store. You are looking for EQ Smart-Level. From there simply follow the provided instructions. The operation of the system from a smart phone is the same as from the control panel with the exception that you cannot do the orientation or null programming from the Blue Tooth.

## Panel Indicator LED's

During typical operation, the LED's on the bottom left hand corner of the keypad should NOT be illuminated. The only LED that should light is the OPERATING LED, which should flash during operation.

POWER LED	ON Red when power is ON OFF when power is OFF FLASH every 1 sec. in sleep mode
JACK LED	ON Red when jack(s) are deployed OFF when jack(s) are stowed
OPERATING LED	ON Red w/Auto-Level or All Retract OFF when keypad is idle or sleeping
LOW VOLTAGE LED	ON Red when voltage is below 10.5 VDC OFF when voltage is above 10.5VDC
ENGAGE PARK BRAKE LED	ON Red when park brake is not set OFF when park brake is set
IGNITION ON LED	ON Red when ignition is in the ON position OFF when ignition is off
EXCESS SLOPE LED	ON Red following an Auto-Level attempt, if system cannot overcome slope OFF when slope is not excessive

If the LOW VOLTAGE, ENGAGE PARK BRAKE, IGNITION ON or EXCESS SLOPE LED's illuminate, you have an error condition that must be corrected prior to operating the jacks.

It is imperative that the ignition on light operates as described. If not, then a possible unsafe condition may exist.

Note: After an auto level process the operation light should turn off and the Excess Slope light should be off. This indicates that the system has finished leveling and is within the .5-degree (approx. 7/16 inch over 4 feet) front to rear and side to side leveling specification.

If the Excess Slope light is on, then the system was not able to complete the process within the .5-degree specification. There are several possibilities to include but not limited to Low Voltage, jack(s) running out of travel or system/component failure.

## Manual Override for Pump #s 2390, 2532, 2542, 2015, 2017

Your hydraulic motor may be equipped with a manual override output shaft. You must use a drill with a 7/16" or ¼" Allen driver.

The drill must be capable of producing a minimum of 2000 r.p.m. for the pump to develop appropriate pressure output.

Your pump assembly may have a hand pump in place of the motor with manual override shaft. If this is the case, you may pump the hand pump in lieu of using the 2000 r.p.m. drill and the 7/16" or ¼") socket driver.

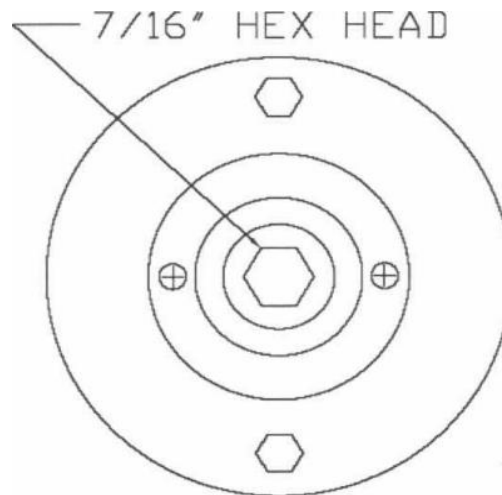

END VIEW OF MOTOR

Care must be taken to ensure neither the drill nor the socket contact any wires or hydraulic hoses while in use.

Note: Pump # 1551 will not have the above hex for the drill.

The hand pump may be found on pump #s 1551, 2015, 2017

## Manual Override for Uni-Directional Pump #'s 1551, 2017, 2015

The individual cartridge valves are clustered together on the side of the pump manifold. They are labeled 1 thru 4. Locate the screws on the appropriate cartridge valve(s). Using a small flat blade screwdriver or 1/8" Allen wrench, turn the screw(s) clockwise until seated in.

Located Valve DV-2. This will have either an Allen override screw or a red knurled knob. This valve will be on the opposite side of the manifold from the cluster of cartridge valves. If equipped with the Allen screw type, turn the Allen screw in until seated in. If equipped with the red knurled knob, pull the red knob out and turn ¼ turn clockwise. The knob will remain in the 'out' position.

To retract: locate DV-1. This valve will be on the adjacent side of the manifold to the cluster of cartridge valves. Pull the red knob out and turn ¼ turn clockwise. The knob will remain in the 'out' position.

### If equipped with override hex on motor: Pump #s 2015, 2017

Remove the black plastic cap from the end of the motor (Can use a small flat head screwdriver). Place the drill with the 7/16" socket on the manual override shaft located at the end of the motor. Run drill in a clockwise direction at 2000 r.p.m.(minimum). The jack(s) will retract.

Following manual override operation, failure to return all valves to normal position may result in one or more jack legs drifting down from their retracted (stowed) position. For cartridge valves, rotate the center screw fully counter-clockwise. For directional valves, rotate the red knob until it 'snaps' back to the normal position or return the Allen screw to the original "out" counter-clockwise position.

\*Note: The normal operating position of the screw in the cartridge valve(s) is the counter-clockwise 'out' position. The only time the valve should be shifted manually is when attempting to operate jack(s) via manual override.

\*\*Note: The normal operating position of the red knob on the directional valve(s) is the 'in' position. The only time the valve should be shifted manually is when attempting to operate jack(s) via manual override.

### To extend the Jack(s):

To extend the jack(s), follow all the above steps EXCEPT DO NOT Manually shift directional valve DV1 as described in step # 3 above.

### Manual Override for Bi Rotational Pump #s 2390, 2532, 2542, 3043 and 3195

Your hydraulic pump is equipped with a Bi Rotational motor. You will use a 2000 r.p.m. drill and a 7/16" socket or ¼" Allen Driver. Care must be taken to ensure neither the drill nor the socket contact any wires or hydraulic hoses while in use.

### To operate your jack(s) using the manual override (with bi-rotational motor)

The individual cartridge valves are clustered together on the side of the pump manifold. They are labeled 1 thru 4. Locate the screws on the appropriate cartridge valve(s). Using a small flat blade screwdriver or 1/8" Allen wrench, (depending on the valve type) turn the screw(s) clockwise until seated in.

The pump may or may not have a DV-@ valve on the opposite side of the manifold. If it is the Allen type, turn the screw clockwise until seated in. If it has a red knob, pull out on the knob and turn ¼ turn, it should stay in the out position.

There are 3 motor types.

Some motors have a black plastic plug in the end of the motor. Remove this plug by prying with a small screw driver.

Some motors have a foil sticker on the end, remove this sticker.

Some motors have an aluminum cap over the end of the motor, use a Philips screw driver to remove the 2 screws holding this cover.

Place the drill with the 7/16" socket or ¼" Allen on the manual override shaft located at the end of the motor.

To retract your jack(s) run the drill in the counter-clockwise direction. To extend your jack(s), run the drill in the clockwise direction.

Following manual override operation, failure to return all valves to normal position may result in one or more jacks drifting/traveling down from their retracted (stowed) position. For cartridge valves, rotate the center screw fully counter-clockwise.

**Equalizer Systems Limited Warranty Policy**  
**March 2017**

1. Only warranty claims with prior written or verbal authorization from Equalizer Systems will be recognized, all other claims will be denied.
2. Equalizer Systems warrants slide out and leveling system components for a period of **one year** from the date of original sale of the vehicle. This warranty covers defects in material and workmanship only. Equalizer Systems is not liable for any damage due to abuse, neglect, misuse, negligence, misapplication, error of operation, accidental or purposeful damage or damage due to an "act of God" such as, wind or rain damage, flood, lightning or other natural occurrence of the like. Equalizer Systems limited warranty is applicable to the Equalizer Systems components only and does not apply to the vehicle, apparatus or property to which it is attached. Warranty parts will be shipped at no charge if the repair is authorized by an Equalizer Systems representative. Purchased components used in authorized warranty repairs will be reimbursed at the original purchase price.
3. Labor and freight expenses due to warrantable parts defects or workmanship will be reimbursed for a period of **one year** from the date of original sale of the vehicle. Freight expenses will either be prepaid by Equalizer Systems or reimbursed at the UPS Ground rate only. Any additional shipping charges or requirements are the obligation of the vehicle owner or service center performing the warranty repair. The owner or service center's obligation may include overseas shipping charges, border fees, brokerage fees and any other additional fee of the like.
4. Warranty labor will be reimbursed only for claims that have prior written or verbal authorization from an Equalizer Systems representative. Warranty labor compensation is required to correspond with the "Warranty Parts Replacement Time Guideline" published by Equalizer Systems. Any warranty repair not listed on this guideline will require prior authorization from an Equalizer Systems representative. A reasonable time allowance will be determined by the Equalizer Systems representative. Any warranty repair that is not listed on this guideline that is performed without prior authorization will be denied without exception. Time associated with learning about the repair or excessive diagnostic and installation time will not be reimbursed. Warranty labor will be reimbursed at the authorized service center's published shop rate if the rate is reasonable for that region. Overtime labor will not be reimbursed without exception.
5. Labor, parts and freight credit (if applicable) will be sent after the parts are tested and the warranty claim is validated. Returned parts that are found to be in normal operating condition are not warrantable and will be charged to the owner or service center. Equalizer Systems reserves the right to charge back the service center for labor claim payments previously submitted if the installation of the warranted part is found to be inadequate at a later date.
6. Claims will be denied if the date submitted is greater than 30 days from the repair date.
7. Prior authorization is required before parts may be sent back to Equalizer Systems. A Return Authorization Number is required for items to be accepted.
8. Complete systems are not warranted unless authorized by an Equalizer Systems representative. There are absolutely no exceptions to this clause.
9. Warranty coverage for parts or systems sold by non-authorized resellers (such as live or internet auctions) will be at the discretion of Equalizer Systems.
10. Equalizer Systems is not liable for loss of time, manufacturing costs, labor, material, loss of profits, direct or indirect damages incurred by the vehicle manufacturer.
11. Excessive warranty labor resulting from inadequate access to the Equalizer Systems product will not be reimbursed.
12. Equalizer Systems will not pay a markup on warranty parts unless required by law.
13. Travel expenses, hotel, telephone, fuel or any other expenses of the like are not covered under warranty.

**Replacement Parts:**

1. Replacement parts are warranted under the same guidelines listed above for the remainder of the original warranty or 90 days, whichever is longer. Proof of warranty repair date and original vehicle purchase date are required.

No additional warranties, expressed or implied, are authorized by Equalizer Systems

This warranty voids all previous issues.

Questions concerning this warranty should be directed to:

**Equalizer Systems**  
**55169 CR 3 North**  
**Elkhart, IN 46515**  
**1-(800) 846-9659**  
**1-(574) 266-6083 fax**

To activate your warranty, please visit our website at <http://equalizersystems.com/service/activate-warranty>

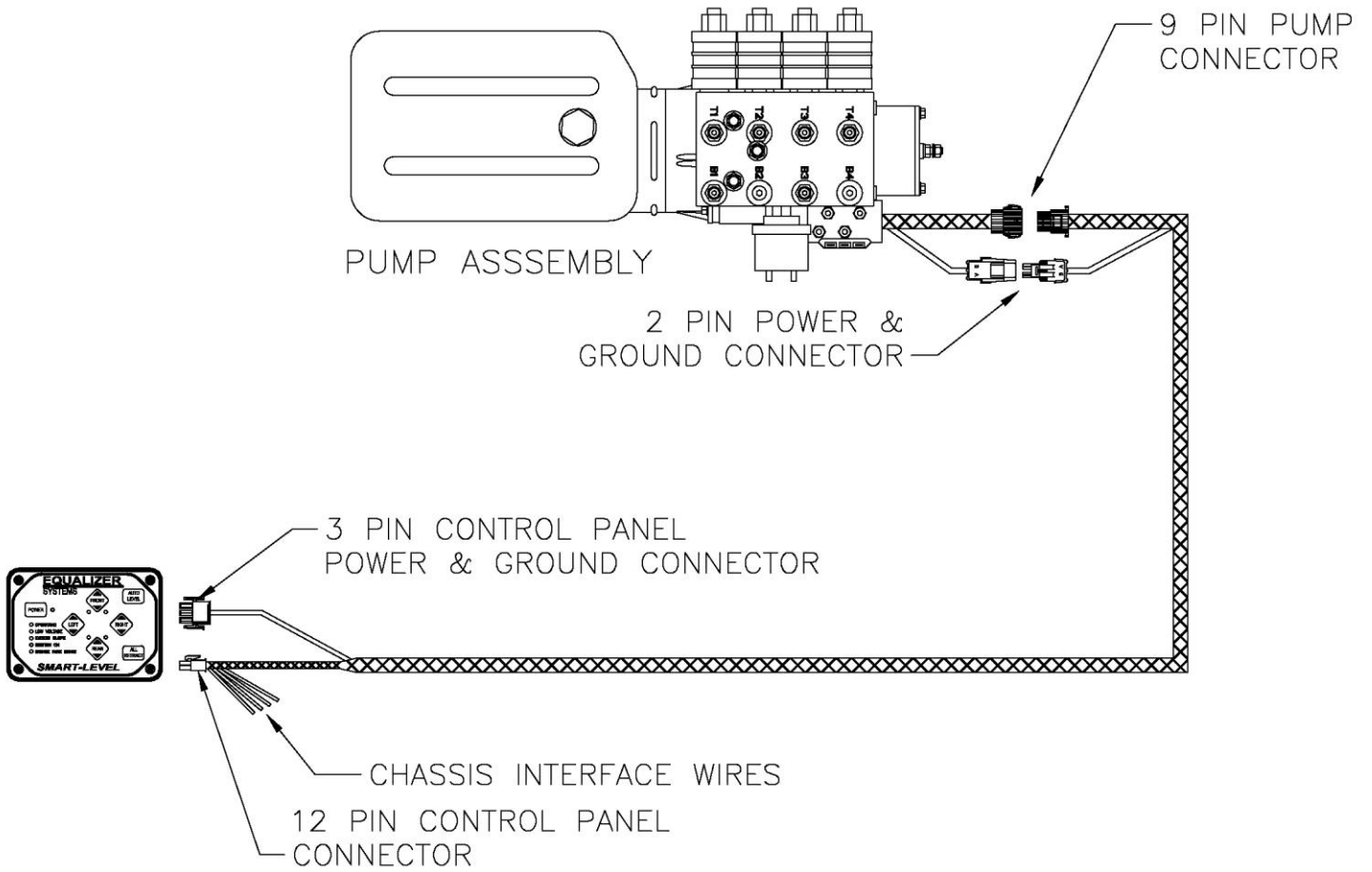

**EQ Smart-Level Control Panel with harness and pump Layout**

# 7982KS PUMP WIRING

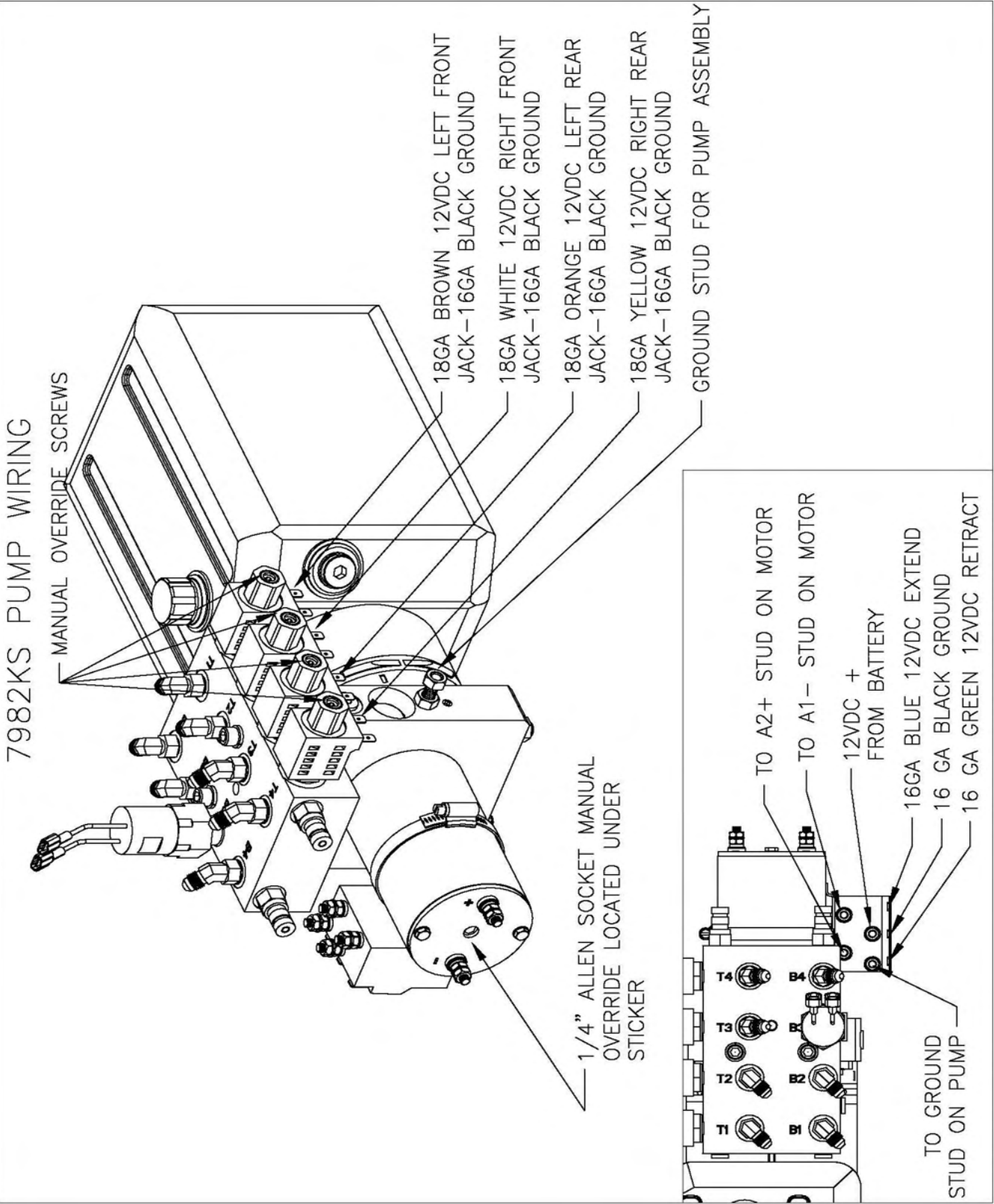



# HYDRAULIC HOSE CONNECTIONS 7982KS PUMP

- B = RETRACT FUNCTION
- B1 = LEFT FRONT JACK (BROWN/BLACK)
- B2 = RIGHT FRONT JACK (WHITE/BLACK)
- B4 = RIGHT REAR JACK (YELLOW/BLACK)

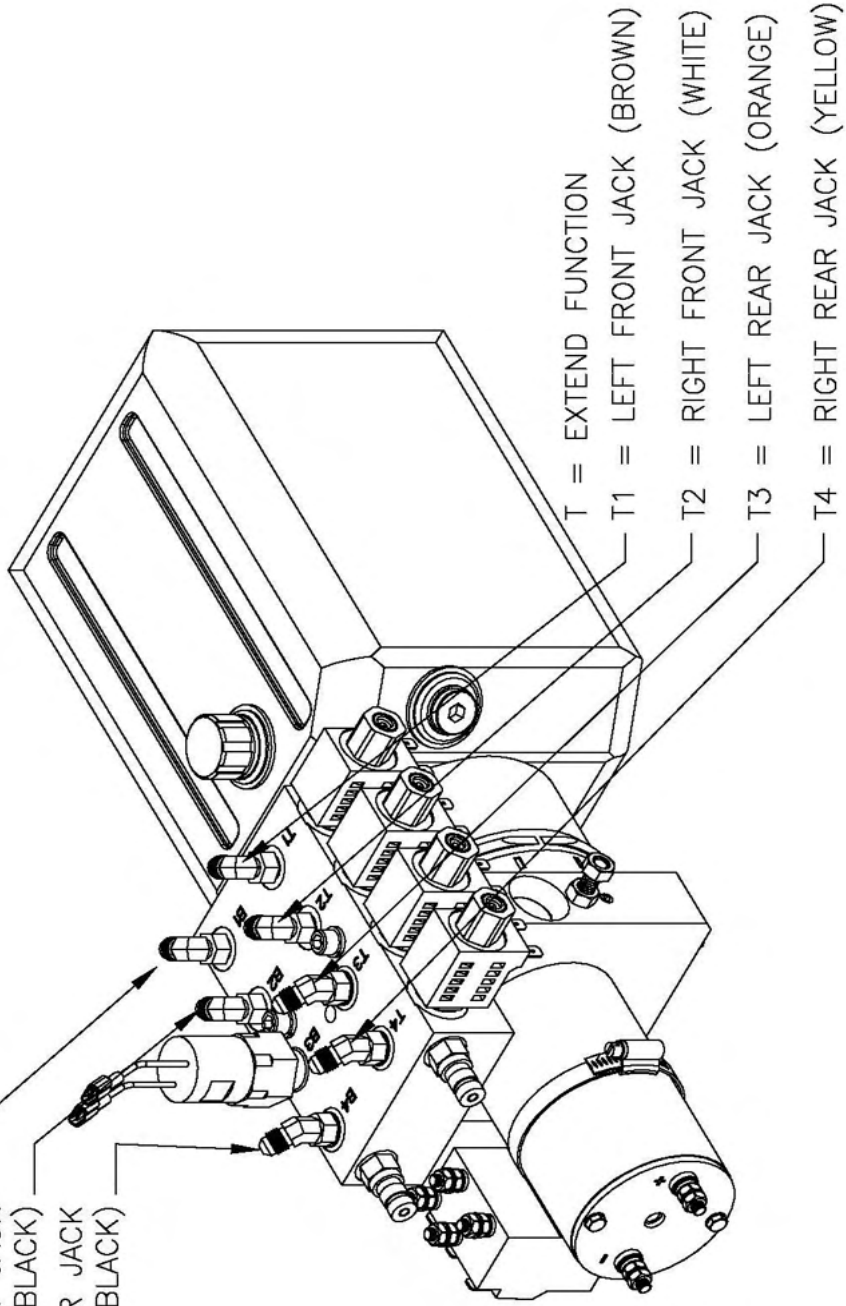

7948KS (3195KS PUMP) WIRING  
MANUAL OVERRIDE SCREWS

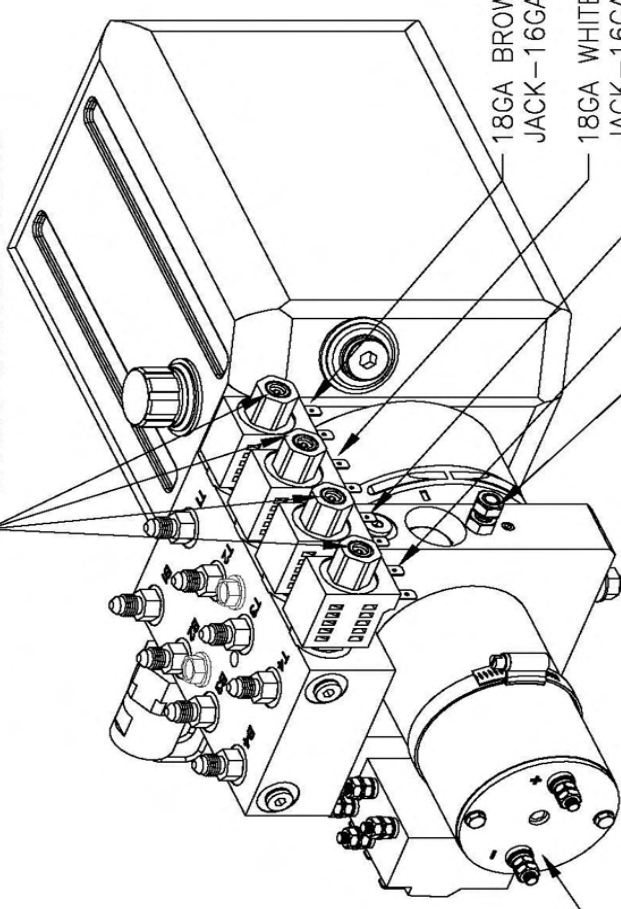

1/4" ALLEN SOCKET MANUAL  
OVERRIDE LOCATED UNDER  
STICKER

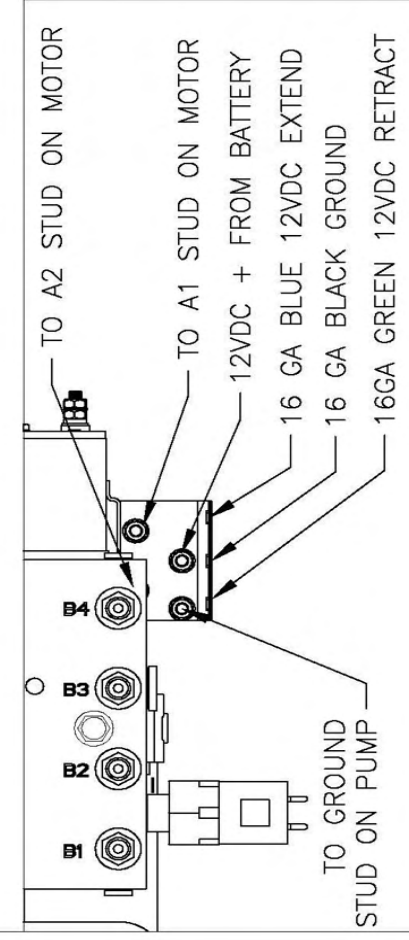

HYDRAULIC HOSE CONNECTIONS  
7846KS (3195KS PUMP)

- B = RETRACT FUNCTION
- B1 = LEFT FRONT JACK (BROWN/BLACK)
- B2 = RIGHT FRONT JACK (WHITE/BLACK)
- B3 = LEFT REAR JACK (ORANGE/BLACK)
- B4 = RIGHT REAR JACK (YELLOW/BLACK)

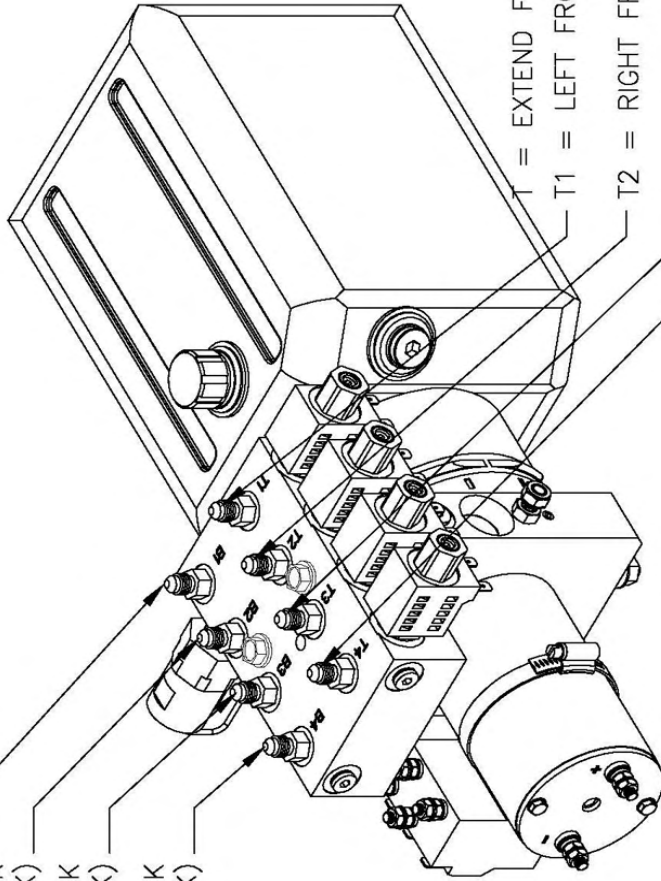

- T = EXTEND FUNCTION
- T1 = LEFT FRONT JACK (BROWN)
- T2 = RIGHT FRONT JACK (WHITE)
- T3 = LEFT REAR JACK (ORANGE)
- T4 = RIGHT REAR JACK (YELLOW)

## Small Bi-Rotational Pump Assembly

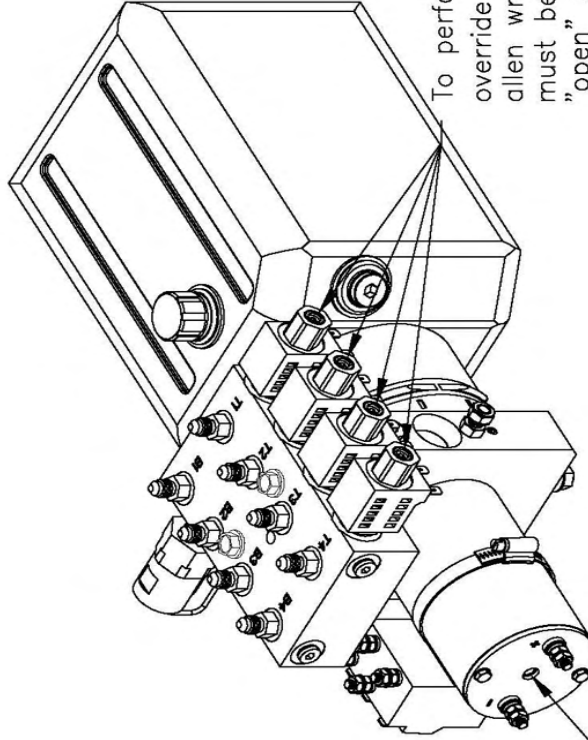

Manual override screw, 6mm allen head, is under this sticker. Using a 2000 rpm minimum drill, retract jacks by turning counter clockwise. To extend, turn screw clockwise.

To perform the manual override procedure, using a  $\frac{1}{8}$ " allen wrench, all set screws must be turned clockwise "open" until they are snug. Once all levelers are retracted, turn all valve screws counter clockwise "closed" until snug.

HYDRAULIC HOSE CONNECTIONS  
7998 (3218 PUMP)

- B = RETRACT FUNCTION
- B1 = LEFT FRONT JACK  
(BROWN/BLACK)
- B2 = RIGHT FRONT JACK  
(WHITE/BLACK)
- B3 = LEFT REAR JACK  
(ORANGE/BLACK)
- B4 = RIGHT REAR JACK  
(YELLOW/BLACK)

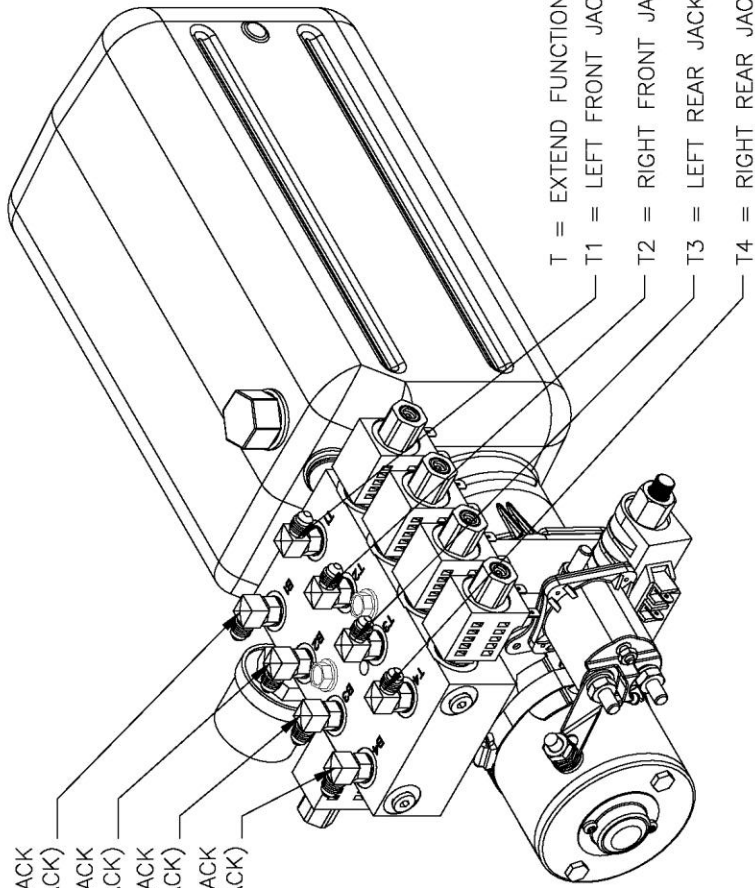

- T = EXTEND FUNCTION
- T1 = LEFT FRONT JACK (BROWN)
- T2 = RIGHT FRONT JACK (WHITE)
- T3 = LEFT REAR JACK (ORANGE)
- T4 = RIGHT REAR JACK (YELLOW)

# 7998 (3218 PUMP) WIRING

